

HIGH EFFICIENCY PULSE WIDTH MODULATOR Z18350

Installation instructions for Northern Radiator high efficiency pulse width modulator. 40A rated continuous operation.

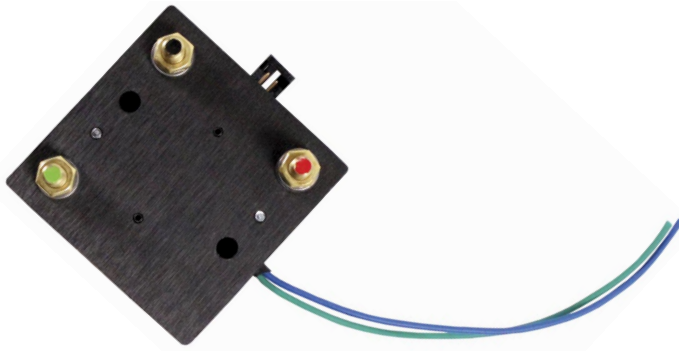

Warning! This product can expose you to chemicals such as styrene which is known to the State of California to cause cancer. For more information, visit [www. P65Warnings.ca.gov](http://www.P65Warnings.ca.gov)

WARNING:

Working with high power electronics is dangerous. If handled improperly, it can lead to fires, injuries, and death. It is imperative above anything else that all appropriate safety measures be used to control the electricity and any fuel sources. Proper XLPE insulated wiring and high-quality connections must be used in accordance to the manufacturer's specifications and routed away from any potential sources of mechanical damage. If you are unsure about your work or safety, stop work immediately and consult with Northern Radiator or a qualified automotive technician.

Thank you for your purchase of the Northern Radiator High Efficiency Pulse Width Modulator Z18350 automotive radiator fan speed controller. This controller allows for automatic, variable speed, soft-start, and constant temperature fan control. Combined with numerous safety features, this controller greatly reduces average fan noise and system power requirements. Careful installation practices will lead to a more reliable, long-term fitment with little need to remove from the vehicle. This controller is intended to be mounted to the inside of an aluminum radiator shroud, between the radiator and the shroud, on the vehicle radiator core support, or separate mounting bracket supplied. The controller cannot be used unless it is mounted to a metal surface that acts as a heat sink.

LIMITED WARRANTY

Northern Radiator warrants its products to be free from defects in material and workmanship under normal use and if properly installed for a period of one year from date of purchase. If found to be defective as mentioned above, it will be replaced or repaired if returned along with proof of date of purchase. This warranty is only valid on products purchased from Northern Radiator or their Authorized Dealers.

The following steps will help to ensure good modulator operation and long life. Careful attention to wire routing, protection, strain relief, connectors, crimps, etc. will lead to a longer lasting and more reliable installation. Be sure to use appropriate personal protective equipment and safe automotive lifting, support, and working methods. A fire extinguisher must be kept available, ready, and functional at all times.

- 1) Disconnect the negative cable from the battery.
- 2) The Northern Z18350 is intended to be mounted inside of an aluminum radiator shroud, between the radiator and shroud, on a flat mounting area. The hole pattern in **Diagram 1** hole mounting should be used. The view is from the engine side. The controller can be mounted in any orientation. **NOTE:** The 1/2" diameter holes must not come into contact with the washers or nuts on the controller or else controller damage and/or shorting will result.

Notes:

- 1) Controller depth 0.68"
- 2) Use #10 x 3/8" maximum length button head screws for mounting
- 3) Heat sink/lid perimeter shown for reference
- 4) Maximum mounting surface thickness 1/8"

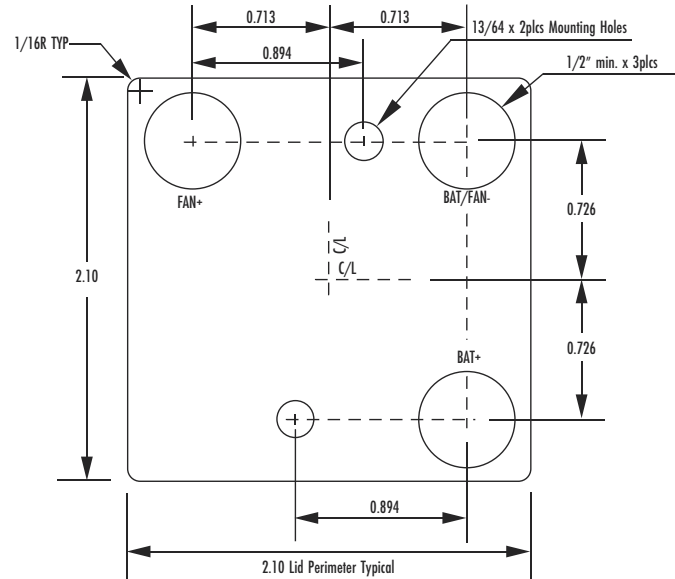

DIAGRAM 1: Hole Mounting

- 3) For plastic shroud or no-shroud applications, the controller must be mounted to the supplied mounting bracket. Use the included rivets and washers to mount the bracket.

See Photo 1

- 4) The radiator core support may also be used for controller mounting.
- 5) Use the #10-24 screws, lock, and flat washers provided to attach the controller to the mounting surface. Full thread engagement into the 1/8" thick lid is required. The screw must not extend farther than 1/4" past the top surface of the controller lid. Tighten the mounting screws to 22 in-lbs.

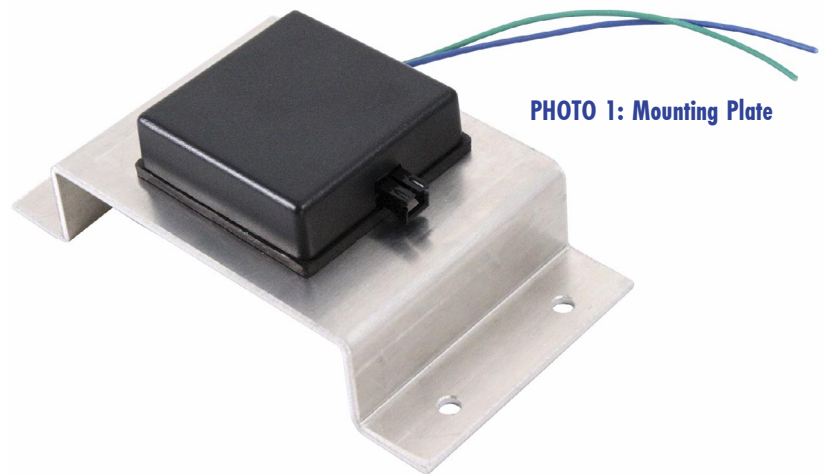

PHOTO 1: Mounting Plate

REFER TO DIAGRAM 2 and 3 FOR STEPS 6-16

- 6) The Z18350 can control single or multiple fans up to a total of 40A continuous load. Connect the fan(s) positive wiring to the controller FAN + lug as shown using #10 ring terminals. The end of the lug is painted green. The order of hardware installation for all terminals is: a) Ring terminal b) Star lock washer c) 5/16" hex brass nut

If twin fans are used, it is acceptable to have both fan positive wires routed to a single heavy duty ring terminal. Proper crimping is essential to providing a secure and electrically conductive connection. Insulate the crimp area using the provided 1/4" diameter x 1/2" long heat shrink in a manner similar to the 10ga power wiring provided. Tighten the brass nut to 22 in-lbs.

- 7) Connect the fan negative wiring to the controller BAT/FAN- lug. The end of the lug is painted black. Similar to the positive fan wiring, it is acceptable to have both fan negatives combined into a single heavy-duty ring terminal. Do not yet tighten the brass nut.
- 8) Using the provided 10ga x 5' maximum length black XLPE insulated wire, attach the installed terminal to the controller BAT/FAN- lug along with the fan negative already attached. Route the other end to a battery negative or heavy duty chassis ground. The ground must be completely free of paint, grease, dirt, etc. This is a high-power connection, so it must be clean and have sufficient parent material thickness to avoid overheating. Cut the wire to the appropriate length, and install the provided ring terminal, heat shrink, and hardware similar to Step 6 and tighten the brass nut to 22 in-lbs.
- 9) Using the provided 10ga x 5' maximum length red XLPE insulated wire, attach the installed terminal to the controller BAT+ lug using the same practices as in Step 6 and tighten to 22 in-lbs. The end of the lug is painted red. Route this wire close to a clean and corrosion free battery positive connection that is capable of supporting 40A minimum continuous current. **Do not use the starter solenoid or alternator lug as a 12V source.** Slide the supplied 1/4" diameter x 1" long heat shrink on to the red wire.

- 10) Using the supplied 14ga x 6" fusible link as a length guide, trim the 10ga red wire to the appropriate length and strip 5/16" of the insulation. Securely crimp the butt end of the fusible link to the 10ga red wire and apply the heat shrink. Attach the other end of the fusible link to the battery positive connection.

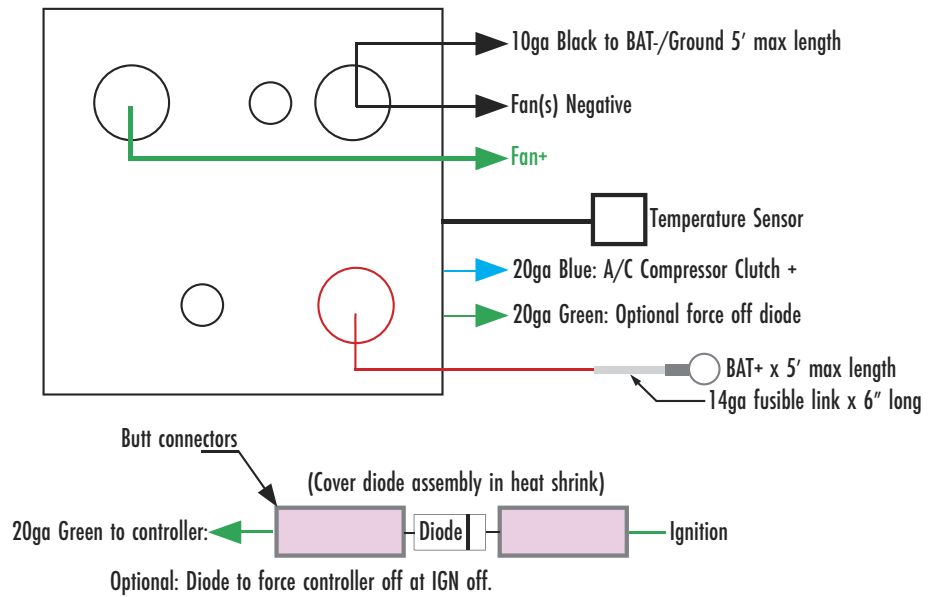

DIAGRAM 2: Wiring Layout

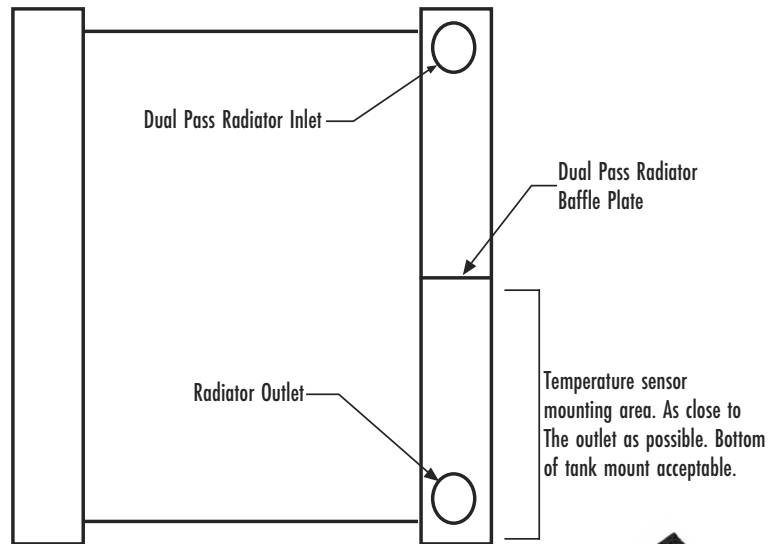

DIAGRAM 3: Wiring Layout

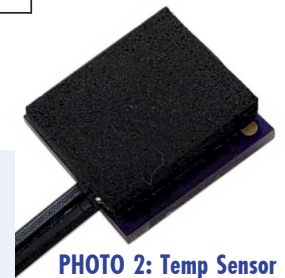

PHOTO 2: Temp Sensor

Diagram 3 and Photo 2.

The temperature sensor must be mounted on the lower 1/2 of the radiator return tank. For radiators where the inlet and outlet are on the same side (dual pass), be sure to mount the sensor below the baffle plate. Mounting the sensor near the outlet will provide the best sensing location.

- 11) Unbundle the temperature sensor wiring harness. Find a suitable flat area to mount the sensor on the lower ½ of the radiator return tank so that the wiring is not under strain. For dual pass radiators be sure that the location is below the blocking plate that separates the top and bottom of the radiator tank. **Placement near the radiator outlet will give the best results.** The sensor can be oriented in any position, so side or bottom placement is acceptable. **See Diagram 3 and Photo 2** for reference.
- 12) Using a Scotchbrite or similar scrubbing pad, scuff the radiator tank sensor mounting area to remove oxidation, grease, etc. Wipe the mounting surface with a clean rag and alcohol. Remove the red peel-off plastic film from the 3M tape, and taking note of the best wire routing angle, press the sensor firmly to the cleaned portion of the radiator tank. If replacement tape is ever needed, a 0.024" thick 3M VHB tape should be used. Do not remove the soft foam tape on the top of the sensor board.
- 13) Route the temperature sensor plug to the connector on the side of the controller and install. Use grommets if the temperature sensor wiring passes through any type of wall (plate, shroud, etc.) Bundle excess wire length and secure.
- 14) For vehicles with air conditioning, connect the 20ga blue controller wire to the compressor clutch positive wire. Pink butt connectors and wiring are provided. This connection will engage the controller to a 50% fan power setting minimum. Fan speed will increase as needed based on temperature sensor input.
- 15) The 20ga green wire can be used optionally to force the controller off. To force the controller off at key-off, connect the supplied diode as shown in **Diagram 2** with the stripe toward an ignition source.
- 16) Finish mounting the shroud, wire routing, etc. to complete the fan/controller installation. Take care to not apply excessive strain to any wiring and to protect it from sharp edges, moving components, etc.
- 17) Re-connect the battery negative cable to the battery.

OPERATION

- 18) The Z18350 controller will automatically, at any time, turn on/off based on the temperature sensed on the return radiator tank unless the shutdown diode in Step 15 is installed. The supplied 180° temperature sensor has shown to work quite well. 160° and 195° sensors are also available.
- 19) As the temperature in the radiator return tank reaches the controller set point, the fan(s) will slowly begin to turn on. This soft start feature greatly reduces the shock to the electrical system, connections, and fan motors. It is normal for the fan(s) to emit a mild high-pitch sound during low duty cycle speeds that is not noticeable during vehicle operation but can be heard during open-hood inspection and high temperature key-off conditions.
- 20) A temperature increase at the sensor of 7° from the sensor set point is needed to force full power to the fan(s). Typical turn on temperatures are 5° above the thermostat temperature. During testing even big brand name temperature gauges were found to be off by as much as 15° vs. actual engine temperature. To help verify thermostat vs. gauge alignment, once the upper radiator hose just starts to warm, that indicates the cracking temperature of the thermostat. Compare that to the temperature gauge. An infrared temperature gun on a flat black surface (upper radiator hose) or checking using an OBD2 port scanner should also yield accurate temperatures.
- 21) If installed without the shutdown diode installed, the fan(s) may continue to operate after key-off allowing for underhood heat to be removed. The fan(s) will typically turn off after less than a minute at very low duty cycles depending on ambient temperatures, radiator and fan heat rejection capacity, and system temperature. Do not attempt to work on the vehicle while the fans are still spinning.
- 22) If temperature sensor removal is needed, twist the sensor radially to help facilitate removal of the 3M VHB tape. When re-installing, use a new piece of tape following the installation instructions for the sensor. Cleanliness is vital for a good connection and proper fan operation. If replacement tape is needed, a 0.024" thick 3M VHB tape should be used.
- 23) The controller will provide an approximate 50% power level to the fans when the air conditioning clutch is engaged. Fan speed will ramp up based on temperature sensor input.